

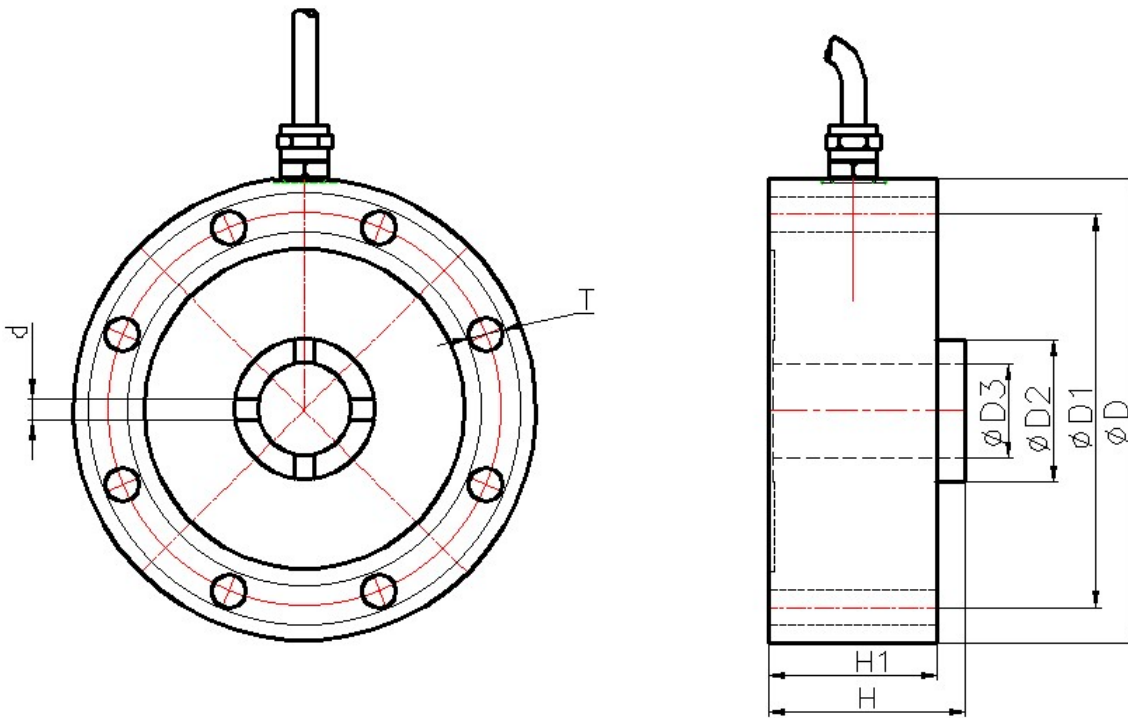

DESCRIPTION

Low profile, suitable for tension and compression using. Small deflection, the compact construction is suitable for withstanding extraneous loads. High permissible dynamic load, protection to IP67.

OUTLINE DIMENSIONS in millimeters (mm)



Capacity	Size mm							
t	D	D1	D2	D3	d	H	H1	T
0.5-10	118	100	36	$24^{+0.20}_{+0.10}$	4×5.1	50	43	8×φ9
20	160	135	62	$40^{+0.20}_{+0.10}$	4×5.1	53	45.5	10×φ14
30	172	147	65	$45^{+0.20}_{+0.10}$	4×5.1	74.5	67	12×φ14

SPECIFICATIONS

Capacity		500kg,1t,2t,5t,10t,20t,30t
Rated output	mv/v	2.0 ± 0.1%
Non-linearity	%F.S	0.05
Hysteresis	%F.S	0.05
Creep in 30 minutes	%F.S	0.05
Zero balance	%F.S	± 1
Input resistance	Ω	385 ± 20
Output resistance	Ω	350 ± 3
Insulation resistance	MΩ	≥ 5000
Excitation voltage	V	10V (maximum 15V) AC/DC
Environmental protection		IP67
Safe overload	%F.S	150
Ultimate overload	%F.S	300
Operating temperature range	°C	-10 ~ +40
Material		Alloy steel & Stainless steel
Cable Length	m	5

FEATURE

- Axle-load scale, warehouse scale, experimental machine

Wiring Schematic Diagram

